



Safe hook on & lift off

Able to feeder all future WTG components

Proven technology

Jones act compliant

3D MOTION COMPENSATED FEEDER

Barge Master's BM-Feeder is the solution for feeding the Next Generation Wind Turbines. This motion compensated platform with its adjustable payload capacity is capable of feeding all Turbine components, including future generations WTG's.

The new BM-Feeder platform uses our patented technology and is based on our existing BM-T700 systems, with a long track record in lifting, drilling and feeder operations.

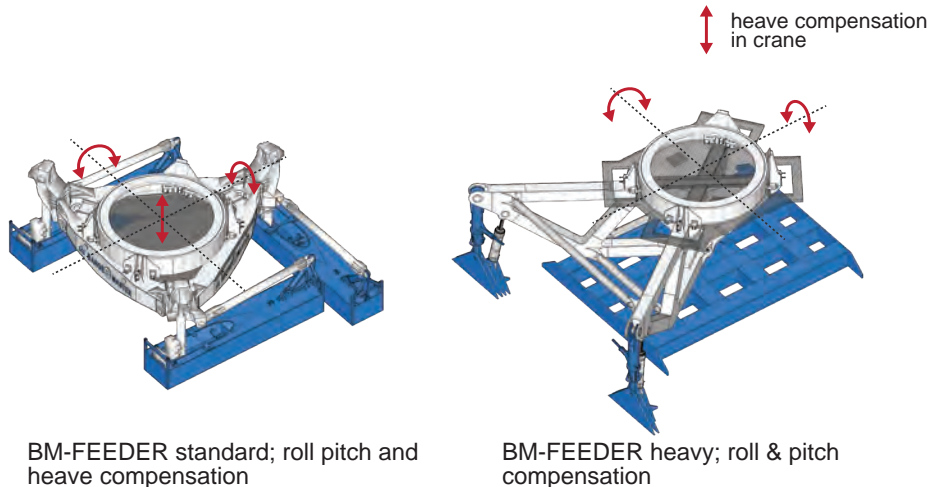

SAFE HOOK ON & LIFT OFF

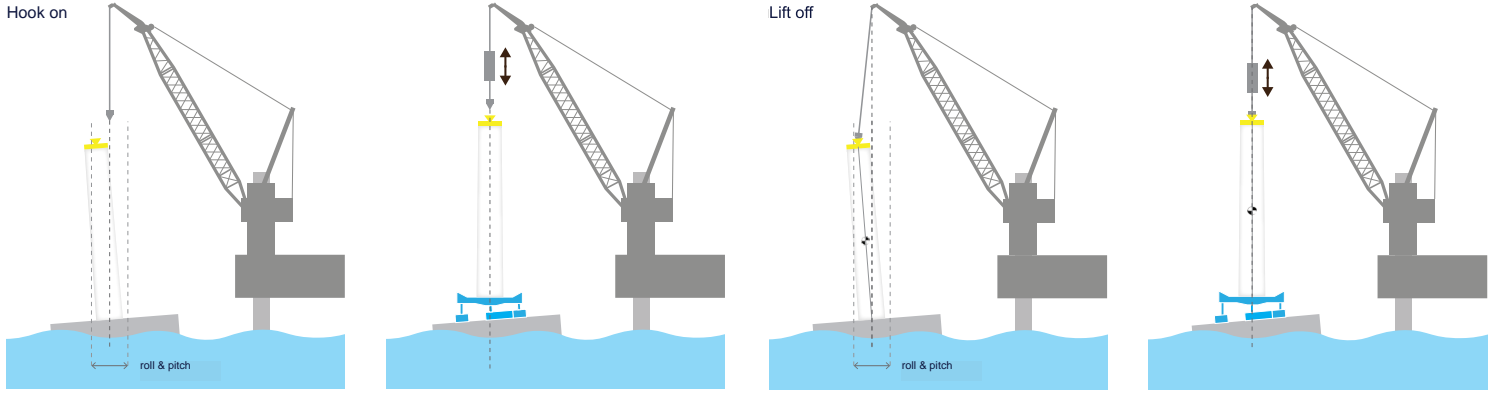

PROVEN TECHNOLOGY

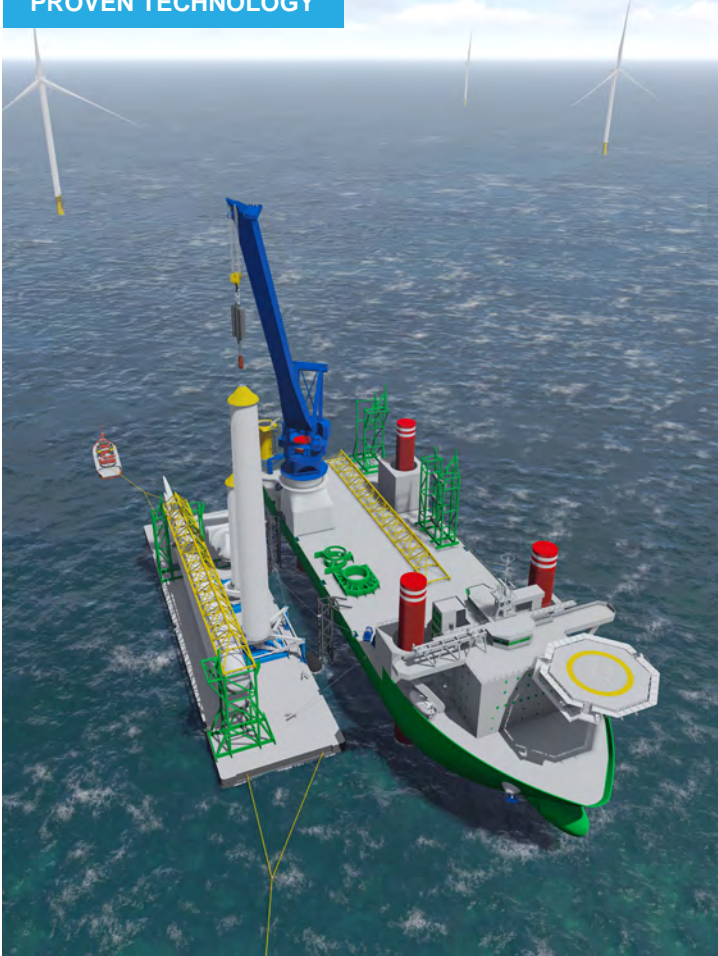

FIT FOR PURPOSE

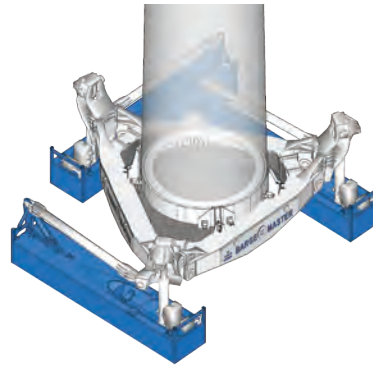

BM-FEEDER STANDARD

GE	Siemens
Haliade X	SG 11.0-200 DD
Tower 1	Tower 1+2
Tower 2	Tower 3+4
Tower 3	
Tower 1+2	
Tower 2+3	

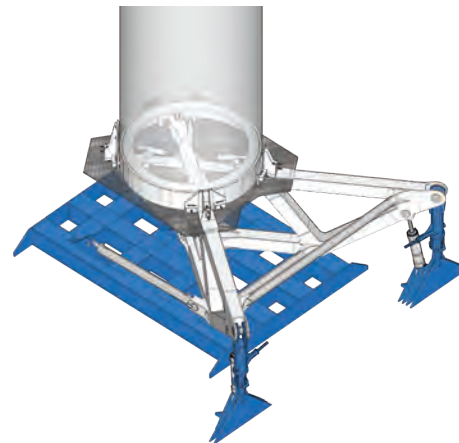

BM-FEEDER HEAVY

GE	Siemens
Haliade X	SG 11.0-200 DD
Tower 1	Tower 1+2
Tower 2	Tower 3+4
Tower 3	
Tower 1+2	
Tower 2+3	

Able to feeder all future generation turbines

GENERAL

- Enables safe hook on
- Enables safe lift off
- Decreases re-impact risk
- Increases workability up to 85%

A quick retract function of the platform can be added
The BM-Feeder will be DNV certified

COMPENSATION

Wave height	Hs 0 - 2.5 m
Wave period	4 - 18 s
Roll and pitch (and heave) motions	95%

CAPACITY

Payload capacity	700 - 1500 mT
Tower diameter	7 - 9 m
Tower heights	up to 80 m

JONES ACT COMPLIANT

The BM-FEEDER can be mobilized on any large U.S. flagged vessel or barge



Barge Master

T +31 (0)10 409 00 60
E info@barge-master.com
W www.barge-master.com

